



MC SERIES

FREESTANDING SPEAKERS
Owner's Manual

Introduction

Congratulations on your purchase of RBH Sound MC Series freestanding speakers! Your speakers are the result of many years of research and development dedicated to producing high quality products for home audio and audio/video systems.

This manual contains features, setup recommendations and specifications for RBH Sound MC Series freestanding speakers. It is recommended you thoroughly read through the material contained in this manual before connecting your speakers. This will ensure you have a good understanding of how to setup your speakers for optimum performance and allow for years of listening enjoyment.

MC Series Freestanding Speakers

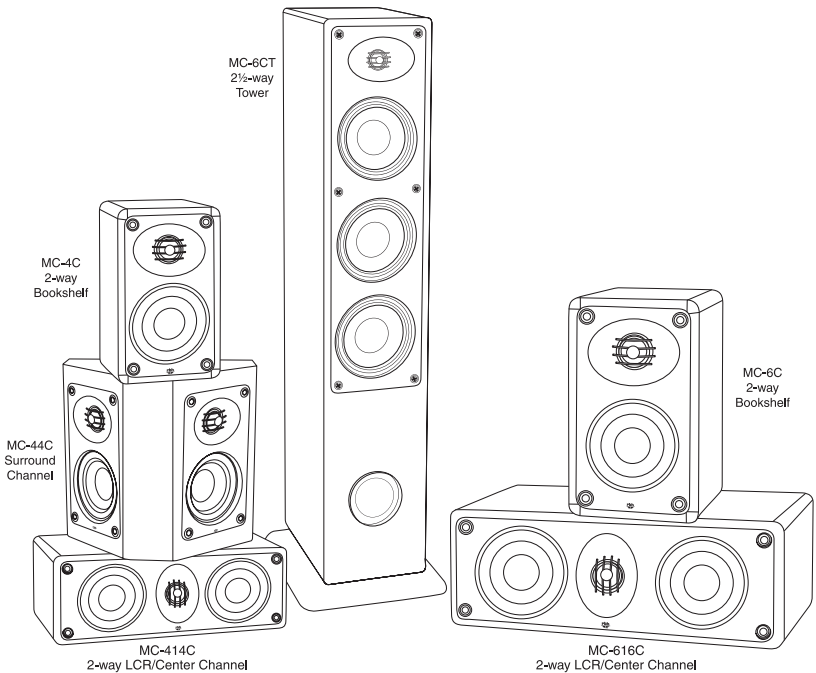

Break In Period

Allow several hours of listening time to adequately break in the MC Series freestanding speakers. As the speaker breaks in, the driver suspension will loosen. The result of break-in will be an increase in low frequency response, improved definition, clarity and detail.

Care and Cleaning

To maintain speaker appearance, we recommend an occasional application of furniture grade polish to the wood surface of the cabinet. To clean dust from the grille cloth, use a vacuum with a brush attachment.

Features

At the heart of the MC Series freestanding speakers is a proprietary aluminum cone bass/midrange driver (speaker). The unique aluminum cone material combines stiffness, low mass and self damping properties in a manner which allows virtually uncolored presentation of program material. A powerful magnet, extended voice coil and bumped back plate give the bass/midrange driver high excursion capability, which ensures accurate dynamic reproduction. The drivers are shielded by using a steel cup and an additional magnet to cancel any stray magnetic field which may cause interference with video equipment such as tube televisions.

For high frequencies, a proprietary aluminum dome tweeter was developed. This tweeter uses liquid cooling, allowing the tweeter to handle greater power while retaining detail and accuracy.

Steep acoustic slope crossovers are used to integrate drivers. The use of steep crossover slopes allows high power handling, minimizes driver interaction anomalies, and maximizes the clarity with which each driver is able to produce its respective frequency band. A polyswitch, or current limiting device, is used in the crossover to prevent damage to the tweeter if overdriven.

Cabinets are constructed of $\frac{3}{4}$ -inch medium density fiberboard due to its inert properties, thereby preventing sound coloration due to cabinet diffraction. The thickness of the front baffles also prevents excess acoustic radiation. To further enhance baffle inertness as well as style proprietary Resonance Damping Alloy Baffle RDAB™ technology is used. Large oversized gold binding posts ensure a good electrical contact. Sophisticated computer modeling and measurement techniques are used extensively in the RBH Sound speaker design process.

Attaching Speaker Wires

When using a banana jack to attach speaker wires to the binding post terminals, insert the speaker wire into the banana jack. Next insert the banana jack into the hole provided in the top of the terminal be sure the nut is tight before inserting the banana jack. Repeat for the other speaker wire(s) as necessary.

If not using a banana jack, simply loosen the binding nut to allow the hole in the side of the terminal to become exposed. Strip $\frac{1}{4}$ -inch of the insulation from the end

Attaching Speaker Wires (continued)

of the speaker wire and insert the exposed wire end into the now exposed hole in the side of the terminal. Tighten the binding nut by turning the nut clockwise until the speaker wire is secured. Repeat for the other speaker wire(s) as necessary. (Refer to the illustration).

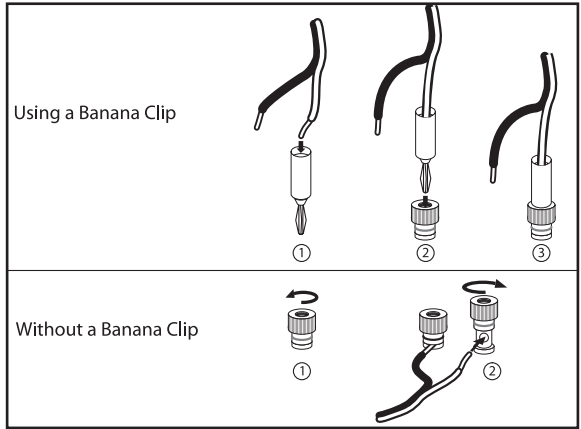

Attaching the Base

As shown below in the illustration, attach the base to the bottom of the MC-6CT tower speaker with the machine screws provided. Also provided are carpet spikes or rubber feet which can be screwed into the bottom of the base. If using the carpet spikes or rubber feet, attach them to the base before attaching the base to the tower. Carpet spikes or rubber feet are optional but will help the speaker stand level and provide better sound quality.

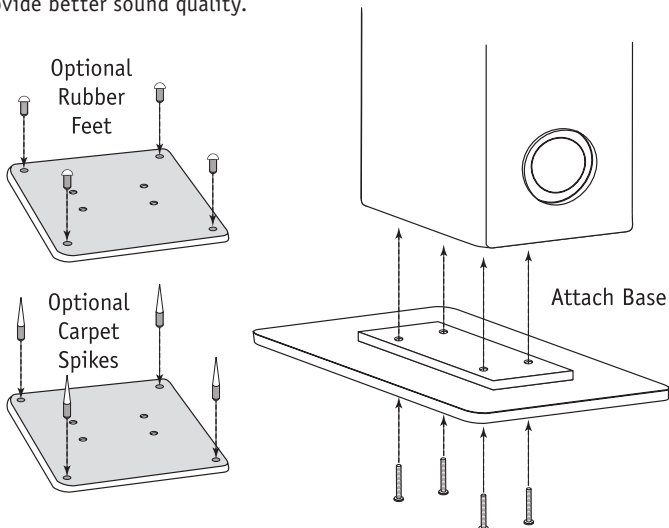

Room Setup Suggestions

In order to extract the best possible sound from your speakers, it is important to determine where the speakers will sound best in your listening room. Room reflections from the floor, ceiling and side walls influence the balance, imaging and overall sonic quality at the listening position. Experiment with speaker placement to determine which location offers the best overall sound. As a general guide, use the room layout diagram on the next page and the following descriptions when setting up a home theater system. Some speakers shown in the diagram may not be applicable to your individual system.

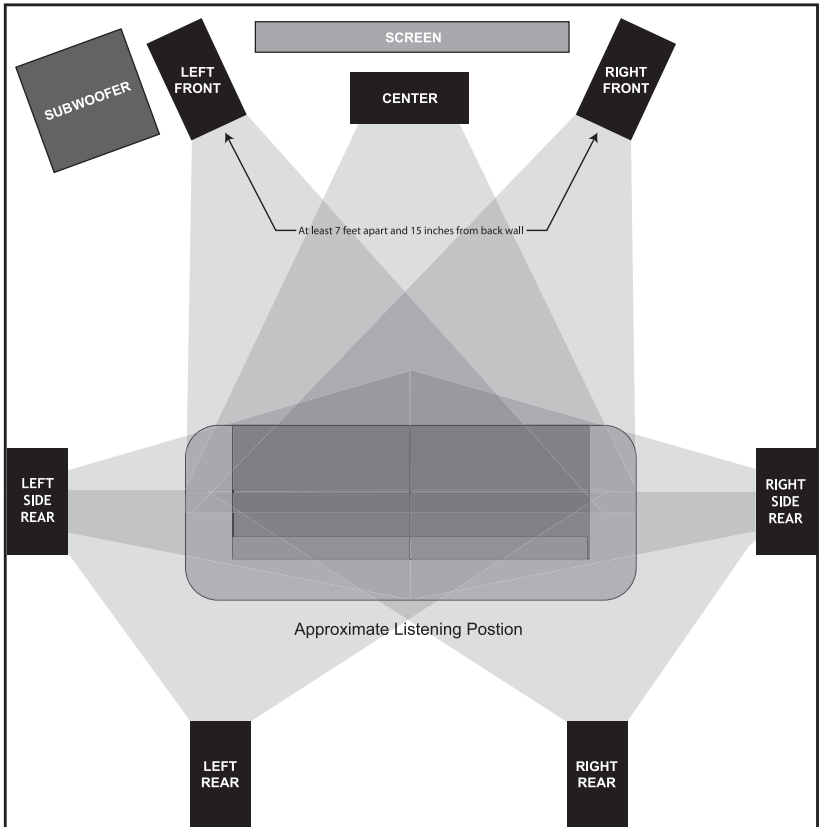

NOTE: There are several different surround formats available. Dolby Pro-Logic, Pro-Logic II, Dolby Digital and DTS generally have a 5 speaker plus subwoofer requirement. Dolby Digital EX and DTS ES add a center rear speaker. Dolby TrueHD and DTS Master Audio available only on Blu-ray disc, generally have a 7.1 requirement. Please consult your audio/video professional to determine which system is best for you and how many speakers you will require.

Room Setup Suggestions (continued)

Front Main Speakers

As a starting point, place your front left and right speakers at least 7 feet apart from each other. The distance from the listening position to each speaker should be close to the distance that separates the two main speakers. Angling the speakers slightly inward towards the listening position may give a more spacious and realistic sound stage.

Center Channel Speaker

The center channel speaker should be placed in the center between both left and right main speakers. Often this positioning dictates placing the speaker either directly above or below a television monitor. If using an MC-414C or MC-616C, the speaker may be in a horizontal (lying down) or vertical position.

Rear Surround Speakers

The surround speakers should be placed either above or behind the listening position. If using the MC-44C, they should be placed slightly above and directly to the sides of the listening position. The listening position should be centered between the surround speakers.

For best performance with the MC-4C and MC-6C models, you may want to experiment with angling the surround speakers either towards or away from the listening position.

Subwoofer

Placement of the subwoofer will largely determine quality, quantity, and extension of the bass frequencies within your listening room. Bass frequencies are reinforced by close room boundaries. Placing the subwoofer in a corner will make the subwoofer sound louder and boost the very lowest frequencies. Placing the subwoofer away from walls will provide the least reinforcement, making the bass sound subjectively thinner. Good results can usually be obtained by placing a subwoofer along a wall 1-3 feet from a corner. Experiment with subwoofer placement and the sub-amplifier controls to achieve the proper bass balance.

Specifications

Model:	MC-4C	MC-414C	MC-44C
Frequency Response:	85Hz-20kHz \pm 3dB	85Hz-20kHz \pm 3dB	100Hz-20kHz \pm 3dB
Sensitivity:	84dB (2.83V/1 meter)	88dB (2.83V/1 meter)	88dB (2.83V/1 meter)
Recommended Power:	50-100 Watts	50-150 Watts	50-150 Watts
Woofers(s):	(1) 4" (102mm) Aluminum Cone	(2) 4" (102mm) Aluminum Cone	(2) 4" (102mm) Aluminum Cone
Tweeter(s):	(1) 1" (25mm) Aluminum Dome	(1) 1" (25mm) Aluminum Dome	(2) 1" (25mm) Aluminum Dome
Impedance:	8 Ohms	6 Ohms	6 Ohms
Crossover Frequencies:	3,000 Hz	3,000 Hz	3,000 Hz
Dimensions:	8½" (216mm) H 5¼" (133mm) W 7¼" (184mm) D	5¼" (133mm) H 14½" (368mm) W 7¼" (184mm) D	9½" (241mm) W 10½" (267mm) H 6" (152mm) D
Grille Color:	Black	Black	Black
Cabinet Finish:	Black Woodgrain	Black Woodgrain	Black Woodgrain
Weight:	7½ lbs. (3.41Kg)	13 lbs. (5.90Kg)	11 lbs. (4.99Kg)
Complimentary In-wall Speakers:	MC-414 (2-way In-wall)	MC-414 (2-way In-Wall)	MC-6DB (Surround In-wall)

Specifications

Model:	MC-6C	MC-616C	MC-6CT
Frequency Response:	50Hz-20kHz \pm 3dB	50Hz-20kHz \pm 3dB	40Hz-20kHz \pm 3dB
Sensitivity:	87dB (2.83V/1 meter)	89dB (2.83V/1 meter)	87dB (2.83V/1 meter)
Recommended Power:	50-150 Watts	50-150 Watts	50-200 Watts
Woofers):	(1) 6½" (165mm) Aluminum Cone	(2) 6½" (165mm) Aluminum Cone	(3) 6½" (165mm) Aluminum Cone
Tweeter:	(1) 1" (25mm) Aluminum Dome	(1) 1" (25mm) Aluminum Dome	(1) 1" (25mm) Aluminum Dome
Impedance:	6 Ohms	6 Ohms	6 Ohms
Crossover Frequencies:	3,000 Hz	3,000 Hz	100 Hz, 3,000 Hz
Dimensions:	12½" (318mm) H 7¾" (197mm) W 8¾" (222mm) D	7¾" (197mm) H 19½" (495mm) W 8¾" (222mm) D	41½" (1054mm) H 7¾" (197mm) W 11½" (292mm) D
Grille Color:	Black	Black	Black
Cabinet Finish:	Black Woodgrain	Black Woodgrain	Black Woodgrain
Weight:	17 lbs. (7.71Kg)	24 lbs. (10.89Kg)	55 lbs. (24.95Kg)
Complimentary In-wall Speakers:	MC-6 (2-way In-Wall)	MC-616 (2-way In-Wall)	MC-616 (2-way In-wall)

Troubleshooting

Situation	Probable Cause	Solution
No sound from speakers.	Speaker wire not connected. Speaker selector on amplifier is not on.	Make sure wire is properly connected at both the speaker and the amplifier observing proper polarity. Activate proper speaker selector on amplifier.
No sound from one speaker.	Balance control on receiver or preamp is not centered. Speaker wire not completely connected.	Place balance control in the center. Check all connections at amplifier and speakers.
Only the woofer or midrange/tweeter are playing.	Bi-amp clips are not intact.	Make certain gold bi-amp clips are in place and tightened down.
Very little bass and/or imaging.	Speakers are wired out of phase.	Check entire system for proper polarity and make adjustments as necessary.

Warranty

Your MC Series freestanding speakers are covered by a limited warranty against defects in materials and workmanship for a period of 5 years. This warranty is provided by the authorized RBH Sound dealer where the speaker was purchased. Warranty repair will be performed only when your purchase receipt is presented as proof of ownership and date of purchase. Defective parts will be repaired or replaced without charge by your dealer's store or the location designated by your dealer authorized to service RBH Sound products. Charges for unauthorized service and transportation cost are not reimbursable under this warranty. This warranty becomes void if the product has been damaged by alteration, misuse or neglect. RBH Sound assumes no liability for property damage or any other incidental or consequential damage whatsoever which may result from the failure of this product. Any and all warranties of merchantability and fitness implied by law are limited to the duration of this express warranty. Some states do not allow limitations on how long an implied warranty lasts, so the above limitations may not apply to you. Some states do not allow the exclusion or limitation of incidental or consequential damages, so the above limitation or exclusion may not apply to you.

Redefining the Way You Experience Sound.TM



382 Marshall Way, Layton, Utah • USA • 84041
Toll Free: (800) 543-2205 • Fax: (801) 543-3300
www.rbhsound.com