



Available in silver or black aluminum

SVTRS includes top bass module

8" aluminum mids in dispersion-averaging alignment

High output AMT tweeter

Mid module designed for sand loading

Eight coats of gloss black polyester

12" reference aluminum sub drivers



THE ULTIMATE PASSIVE LOUDSPEAKER

Your music requires far more than fidelity, it needs **AUTHORITY**. The SVTR and SVTRS combine the ability to play the most subtle nuances with the power of unlimited dynamics.

SVTR: Has one subwoofer module per tower, perfect for medium to large rooms.

SVTRS: Provides an extra subwoofer module on top for added bass output in large rooms.



SVTRS

Each pair of SVTRS towers are a jaw-dropping 92-inches tall and will command any home theater or listening room with such visual and sonic presence, you will become audio-addicted. Four (SV-1212NR) subwoofers join the silky-smooth (SV-831R) reference module speaker in the center of each tower. The power and speed of the proprietary reference, high-excursion 12-inch aluminum cone sub drivers pair seamlessly with the three RBH 8-inch aluminum-cone mid-bass woofers, arranged in a format designed to focus and enhance two channel imaging. We call it "dispersion averaging alignment." You'll simply call it "Amazing." The Air Motion Transformer (AMT) tweeter utilizes a flexible, ultra-lightweight aluminum diaphragm, carefully folded, then suspended in a highly saturated magnetic field, resulting in extremely detailed, high output, upper-frequency response. Passive crossover networks for bi-ampable external amplification are built-in. All are housed in spectacularly beautiful, high-gloss cabinets finished with eight layers of hand-polished piano black polyester. The SVTRS is capable of handling powerful input with ease while delivering a listening experience that truly touches your emotions and senses.

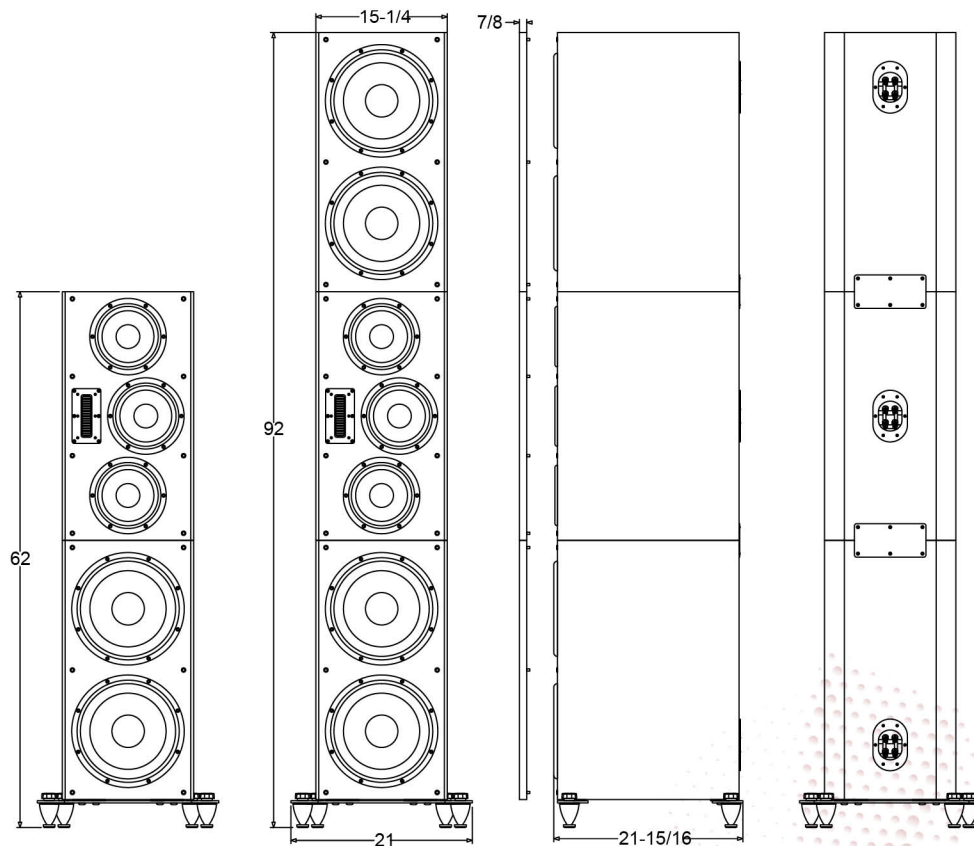

SVTR

SVTRS

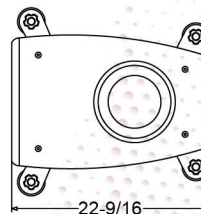

SVTR

SVTR modular towers stand 62". They include one (SV-1212NR) subwoofer and one (SV-831R) reference module speaker per tower. They are identical to the SVTRS, but with less bass output, designed for med to large rooms.

Available in black or silver reference aluminum drivers



*Limited 10 Year Warranty (with registration) from date of purchase to be free from defects and workmanship. For more information contact your RBH dealer or check our website.

It is RBH Sound policy to continuously incorporate improvements into products; all specifications are subject to change without notice.

For the most current information visit us online at <https://rbhsound.com>. Copyright ©2023 RBH Sound. All Rights Reserved.

Model	SVTR	SVTRS
SYSTEM TYPE	Freestanding Modular Tower	Freestanding Modular Tower
FREQUENCY RESPONSE	20Hz-35kHz	17Hz-35kHz
SENSITIVITY <small>(2.83V @ 1 Meter)</small>	93dB	94dB
RECOMMENDED POWER	350-1000 Watts	500-1500 Watts
DRIVE UNITS	1x AMT Tweeter, 3x 8" Aluminum Woofers, 2x 12" Aluminum Subwoofers	1x AMT Tweeter, 3x 8" Aluminum Woofers, 4x 12" Aluminum Subwoofers
TWEETER PROTECTION	Yes	Yes
CROSSOVER FREQUENCY	100Hz, 2000Hz	100Hz, 2000Hz
CROSSOVER SLOPE	6dB/Octave, 18dB/Octave	6dB/Octave, 18dB/Octave
IMPEDANCE	4Ω	4Ω
CABINET/ COLOR	High Gloss Black	High Gloss Black
GRILLE	High Quality Black Cloth	High Quality Black Cloth
WEIGHT	205 lbs (not sand loaded)	312 lbs (not sand loaded)
FINISHED DIMENSIONS	21" W x 62" H x 22-9/16" D (533 W x 1575 H x 574 mm)	21" W x 92" H x 22-9/16" D (386 W x 2337 H x 574 mm)
WARRANTY	*10 Year Limited	*10 Year Limited

RBH Sound • 382 Marshall Way, Ste A, Layton, Utah • USA • 84041
(801) 543-2200 • <https://rbhsound.com>